

BUILDING CODES:
 ALL CONSTRUCTION SHALL COMPLY WITH THE REQUIREMENTS OF ANY AND ALL APPLICABLE STATE, COUNTY AND LOCAL BUILDING CODES OR REGULATIONS INCLUDING BUT NOT LIMITED TO THE FOLLOWING:
 - INTERNATIONAL RESIDENTIAL CODE (IRC) AS ADOPTED AND/OR AMENDED BY LOCAL MUNICIPAL AUTHORITY

ENGINEERING NOTE:
 THERE HAS NOT BEEN ANY STRUCTURAL, MECHANICAL, ELECTRICAL OR SITE ENGINEERING PERFORMED FOR THIS PROJECT. IT SHALL BE THE RESPONSIBILITY OF OTHERS TO OBTAIN DESIGN DATA FROM A LICENSED ENGINEER FOR THESE SYSTEMS. ENGINEERING SHALL CONFORM WITH ALL APPLICABLE LOCAL AND/OR STATE BUILDING CODES AND REGULATIONS.

CONSTRUCTION NOTES:
 - ALL WOOD TO BE PRESSURE TREATED SP #2, OR AS NOTED
 - ALL ROOF BOARDS SHALL BE SECURED WITH (3) 1 1/4" x 7/16" CROWN STAPLES AT EACH FRAMING MEMBER
 - ALL RAFTERS TO BE ATTACHED TO PLATES w/ (5) 2 3/8" RING SHANK NAILS. INSTALL (1) SIMPSON A23Z ANGLE AT EACH RAFTER
 - ALL HARDWARE TO BE GALVINIZED, POWDER-COATED OR STAINLESS STEEL, OR AS NOTED
 - ALL CONCRETE TO BE MINIMUM 3500 PSI

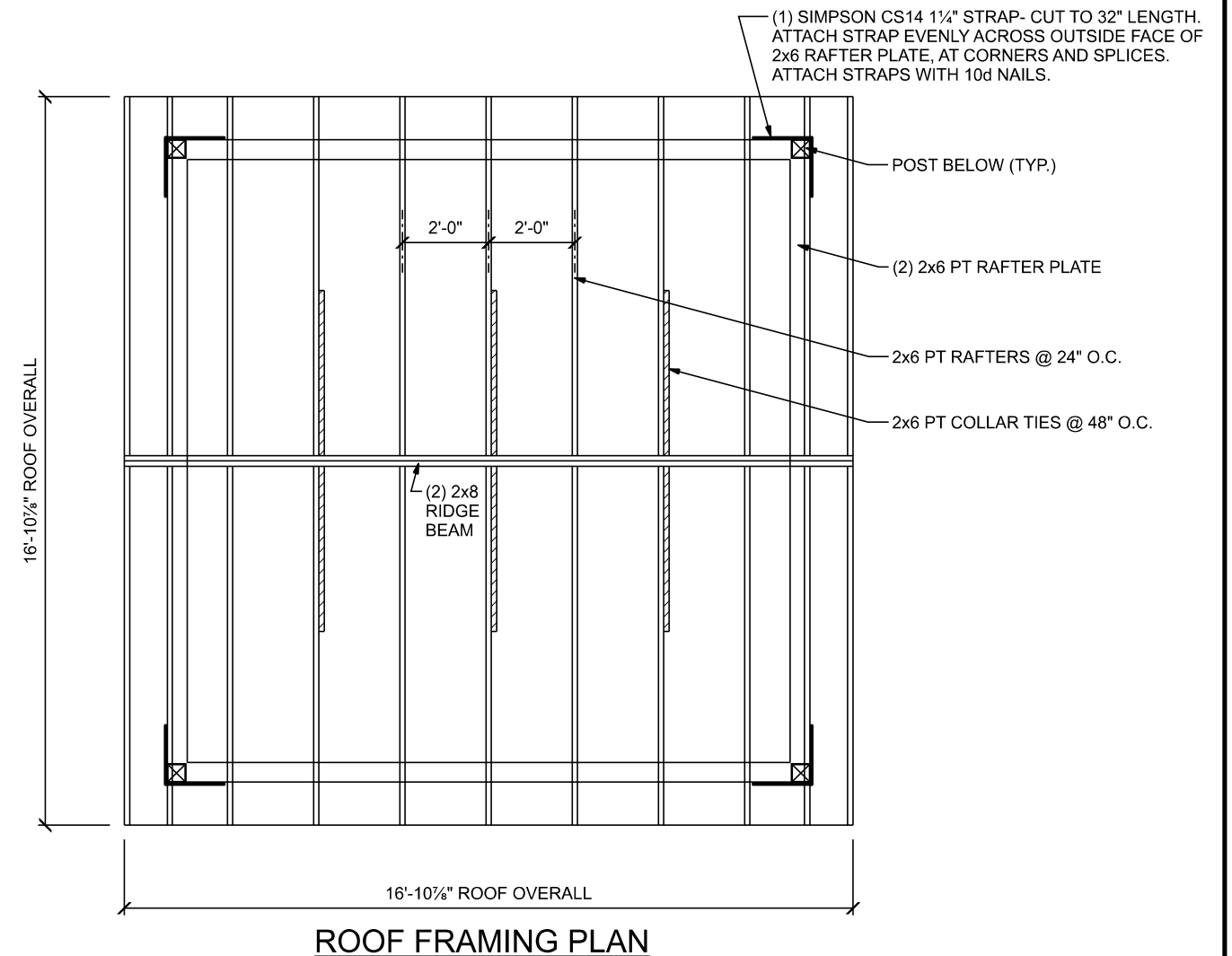

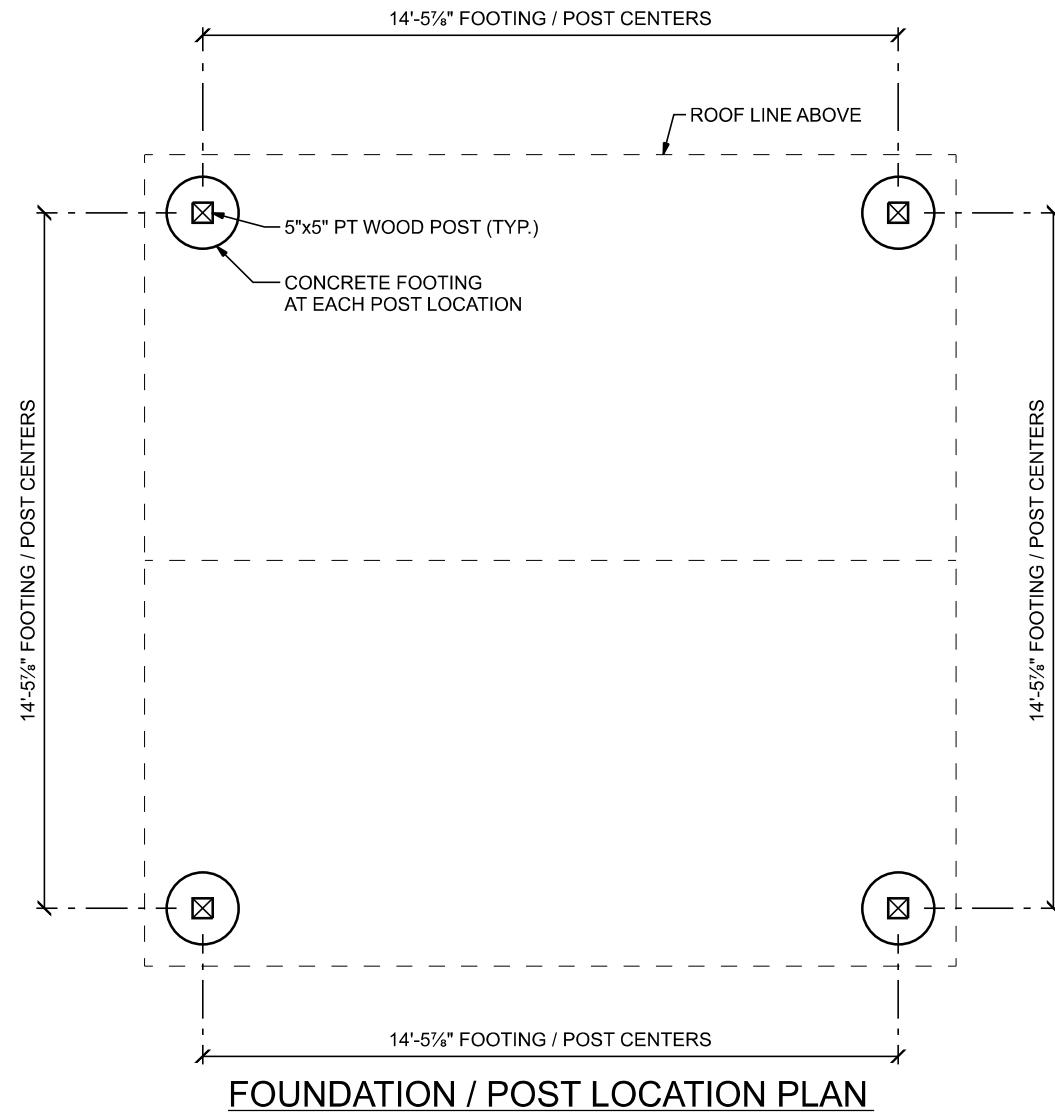
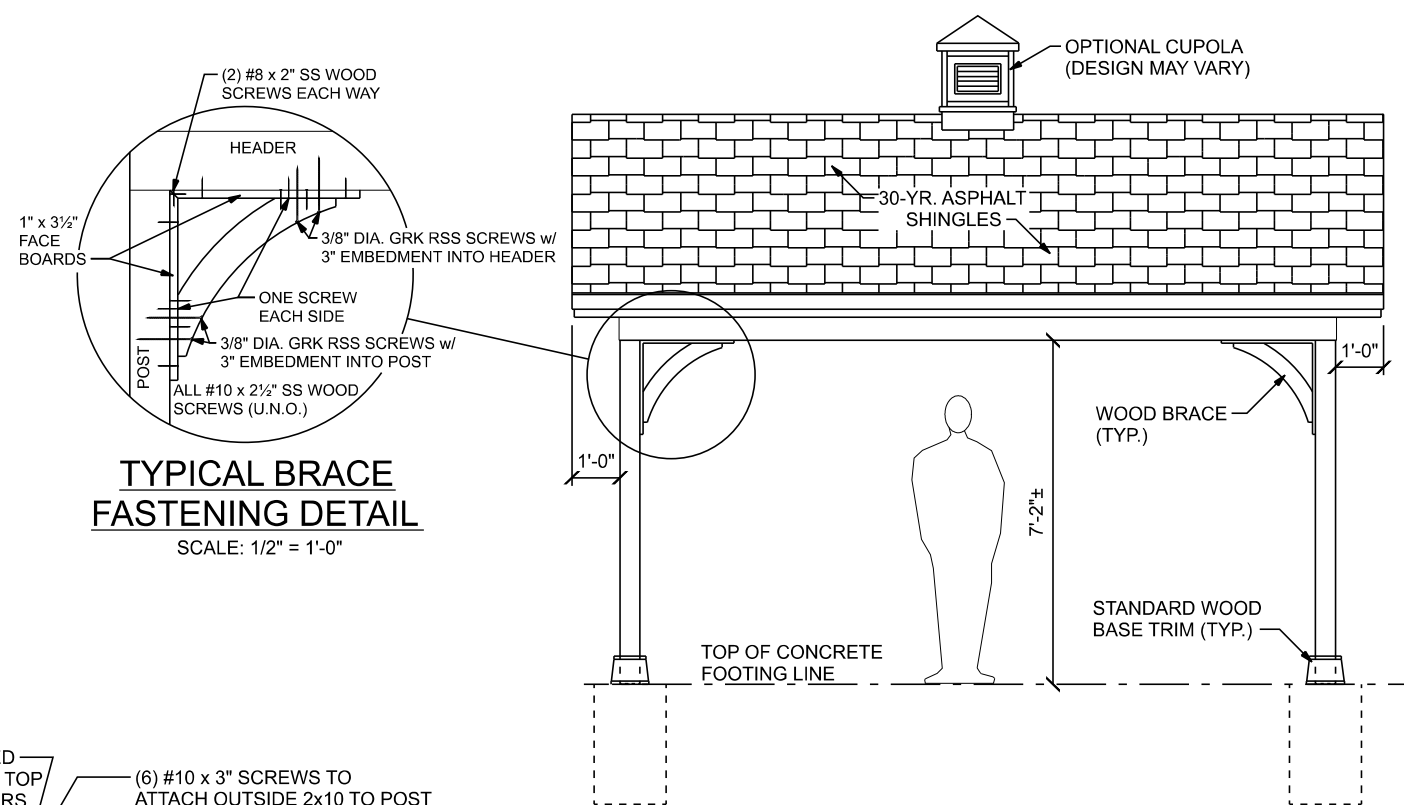

SIDE ELEVATION

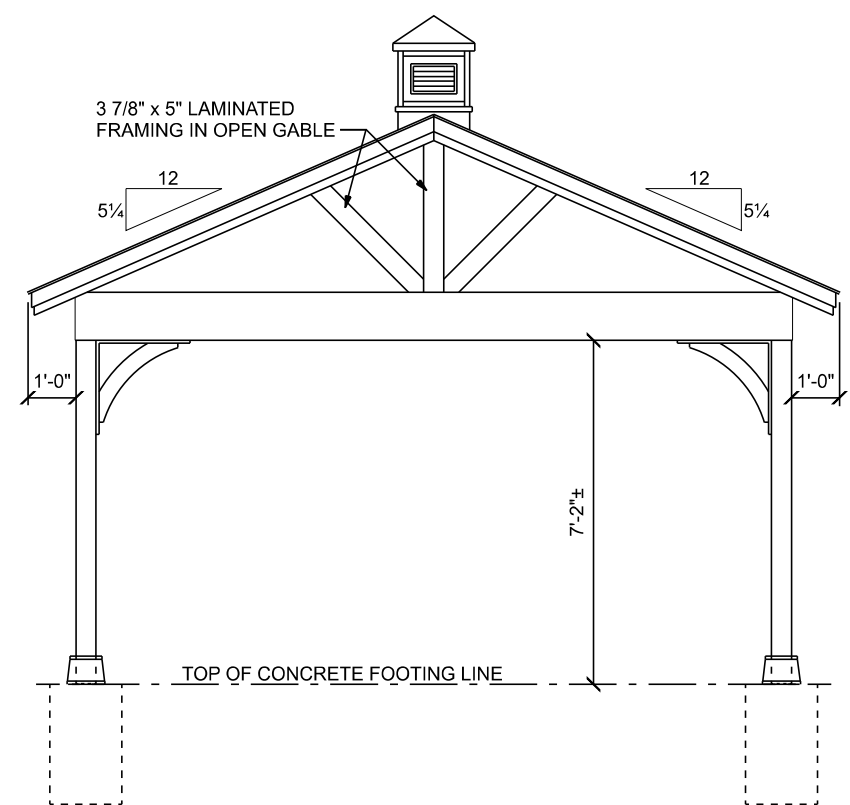

END ELEVATION

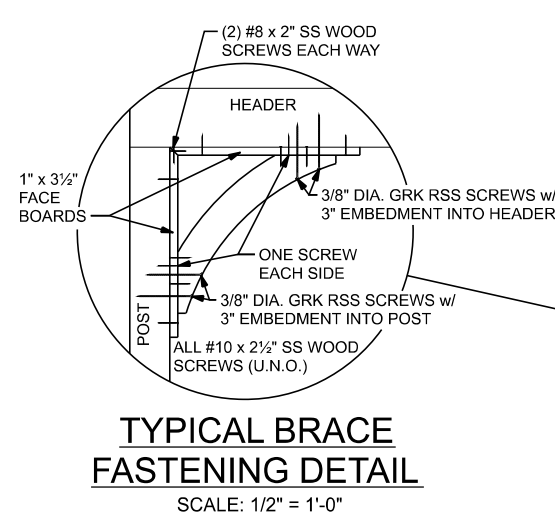

TYPICAL BRACE FASTENING DETAIL
SCALE: 1/2" = 1'-0"

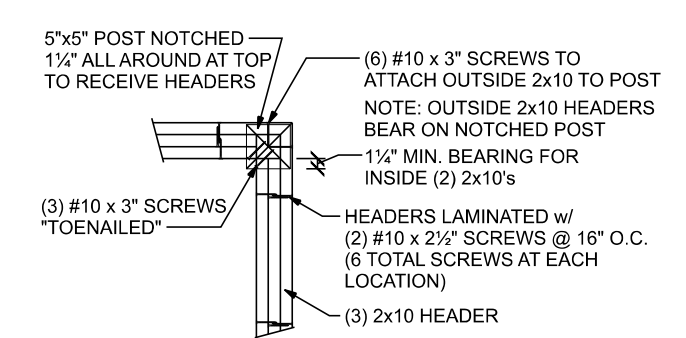

HEADER TO POST CONNECTION DETAIL
SCALE: 1/2" = 1'-0"

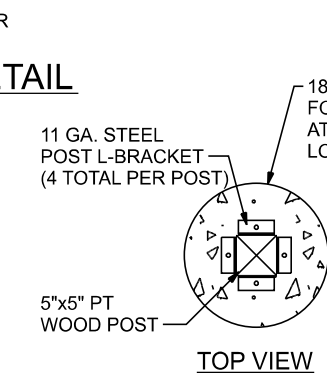

TOP VIEW

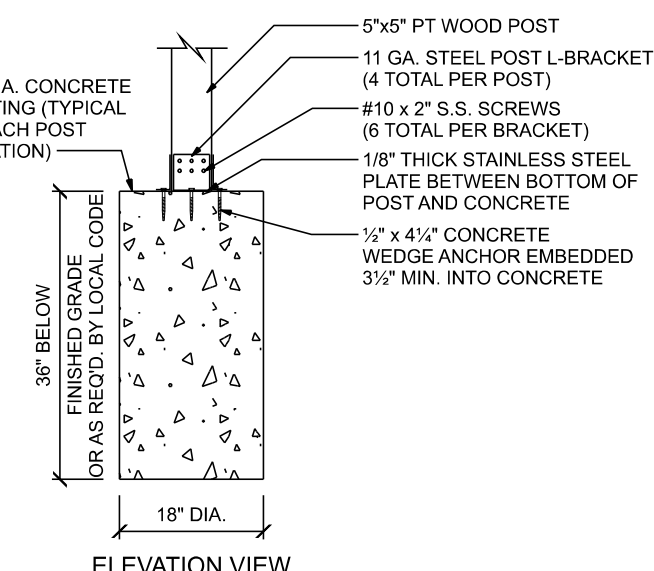

ELEVATION VIEW

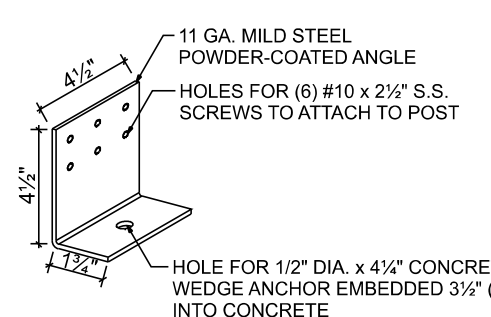

STEEL L-BRACKET DETAIL
NO SCALE

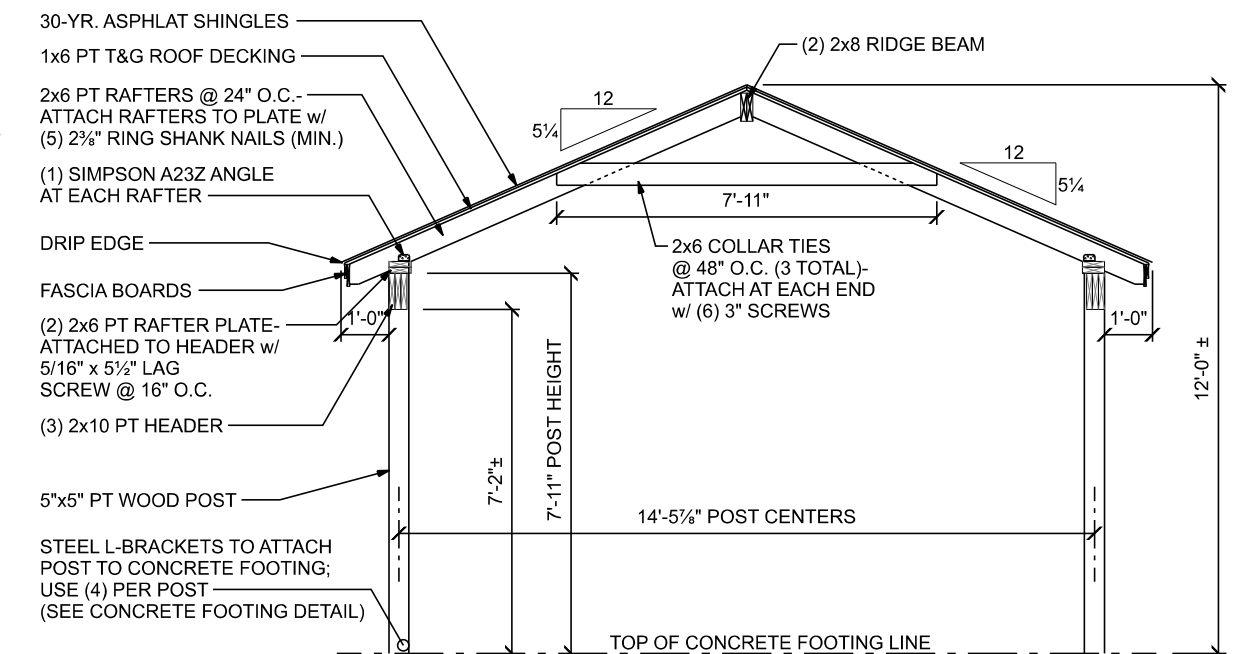

CROSS SECTION

CONCRETE FOOTING DETAIL
SCALE: 1/2" = 1'-0"

www.CREATIVEGAZEBOS.com

SITE LOCATION:

16' x 16' KEYSTONE GABLE PAVILION	
DATE	6/29/2020
REVISIONS	
SCALE	1/4" = 1'-0" U.N.O.
P.N.	10 - 27
SHEET NO.	2 OF 2