

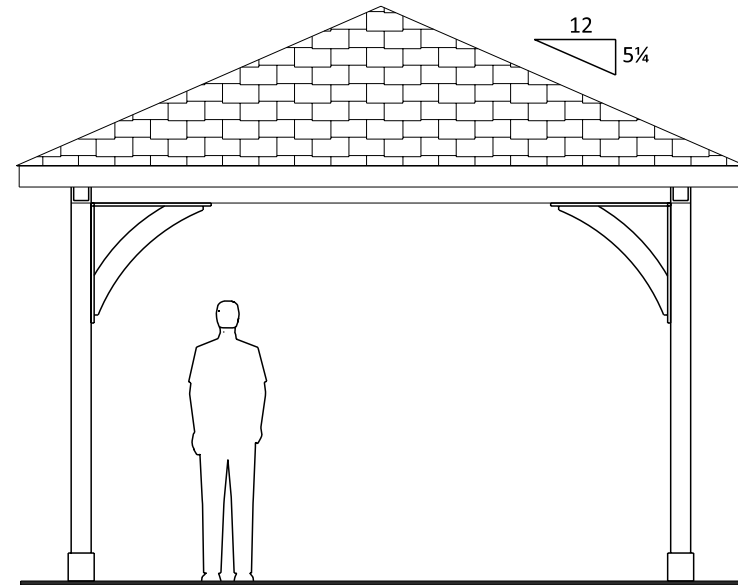

Front Elevation



Side Elevation

CODE & LOADING INFORMATION
 Occupancy Type = Residential Storage
 Construction Type = Type 5B
 Loading Notes = 1st Floor on Grade
 Ground Snow = 30 PSF
 Dead Loads = 10 PSF
 Basic Wind Speed = 115 MPH
 Exposure Class = B
 Seismic Design Category = B
 Frost Line Depth = 36"
 Assumed Soil Class = GM, GC
 Soil Bearing Capacity = 2000 PSF
 If Soil differs from assumed above
 (Refer to IRC Codes)

 Creative Gazebos WWW.CREATIVEGAZEBOS.COM	SITE LOCATION:	14 x 18 Keystone Pavilion (4 post)	
		DATE: Monday, March 25, 2024	
		SCALE: 1/4" = 1'-0"	BY: MERVIN E
			PAGE: 1

BUILDING CODES:

ALL CONSTRUCTION SHALL COMPLY WITH THE REQUIREMENTS OF ANY AND ALL APPLICABLE STATE, COUNTY AND LOCAL BUILDING CODES OR REGULATION INCLUDING BUT NOT LIMITED TO THE FOLLOWING:

-INTERNATIONAL RESIDENTIAL CODE (IRC) AS ADOPTED AND/OR AMENDED BY LOCAL MUNICIPAL AUTHORITY

ENGINEERING NOTES:

THESE DRAWING ARE TO BE USED ONLY AS AN ARCHITECTURAL GUIDE FOR THE CONSTRUCTION OF THIS PROJECT. THERE HAS NOT BEEN ANY STRUCTURAL MECHINICAL, ELECTRICAL OR SITE ENGINEERING PERFORMED FOR THIS PROJECT. IT SHALL BE THE RESPONSIBILITY OR OTHERS TO OBTAIN DESIGN DATA FROM A LICENSED ENGINEER FOR THESE SYSTEMS. ENGINEERING SHALL CONFIRM WITH APP APPLICABLE LOCAL AND/OR STATE BUILDING CODES AND REGULATIONS.

CONSTRUCTION NOTES:

- ALL WOOD TO BE PRESSURE TREATED SYP #1 OR BETTER
 - EACH ROOF BOARD SHALL BE SECURED TO EACH FRAMING MEMBER WITH (3) 1 1/2" X 7/16" CROWN STAPLES (16 GAUGE) OR (2) 8d RING SHANK NAILS
 - ALL HARDWARE TO BE GALVANIZED, POWDER-COATED OR STAINLESS STEEL

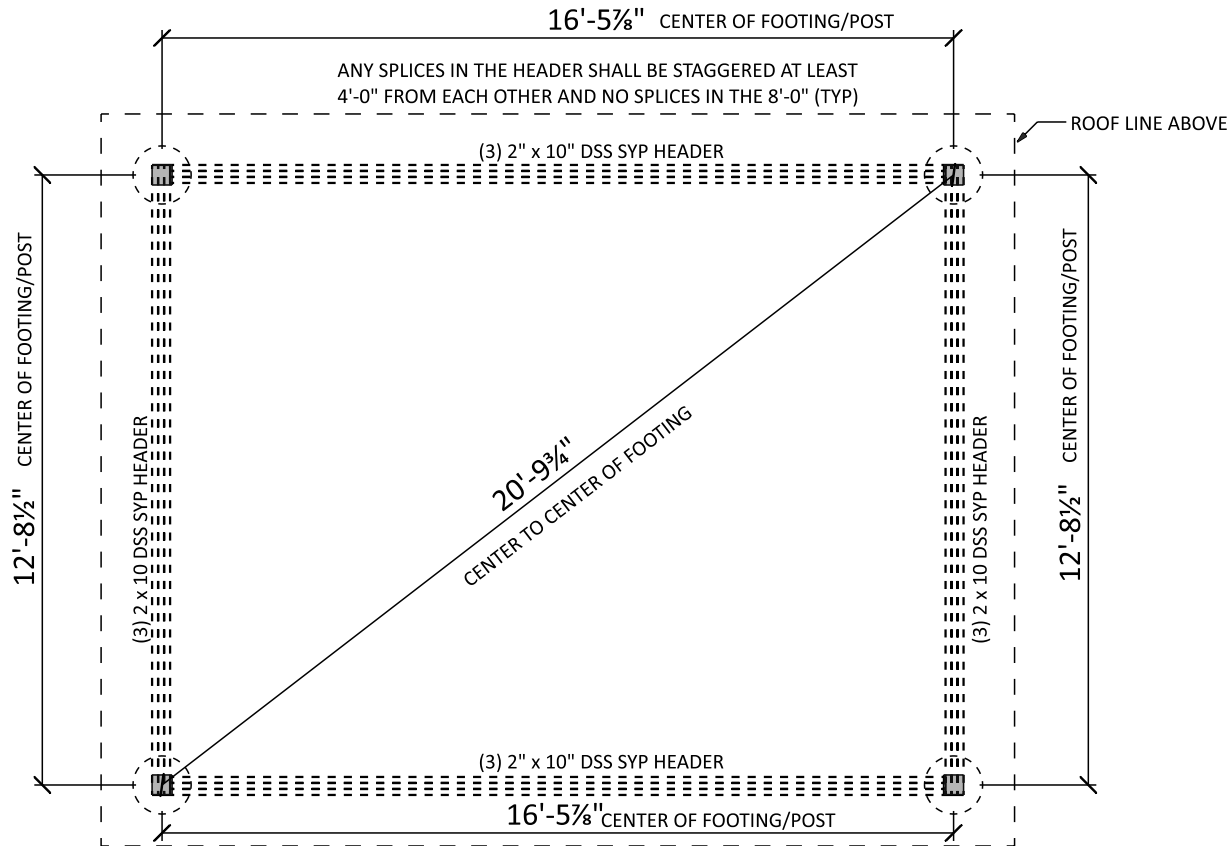

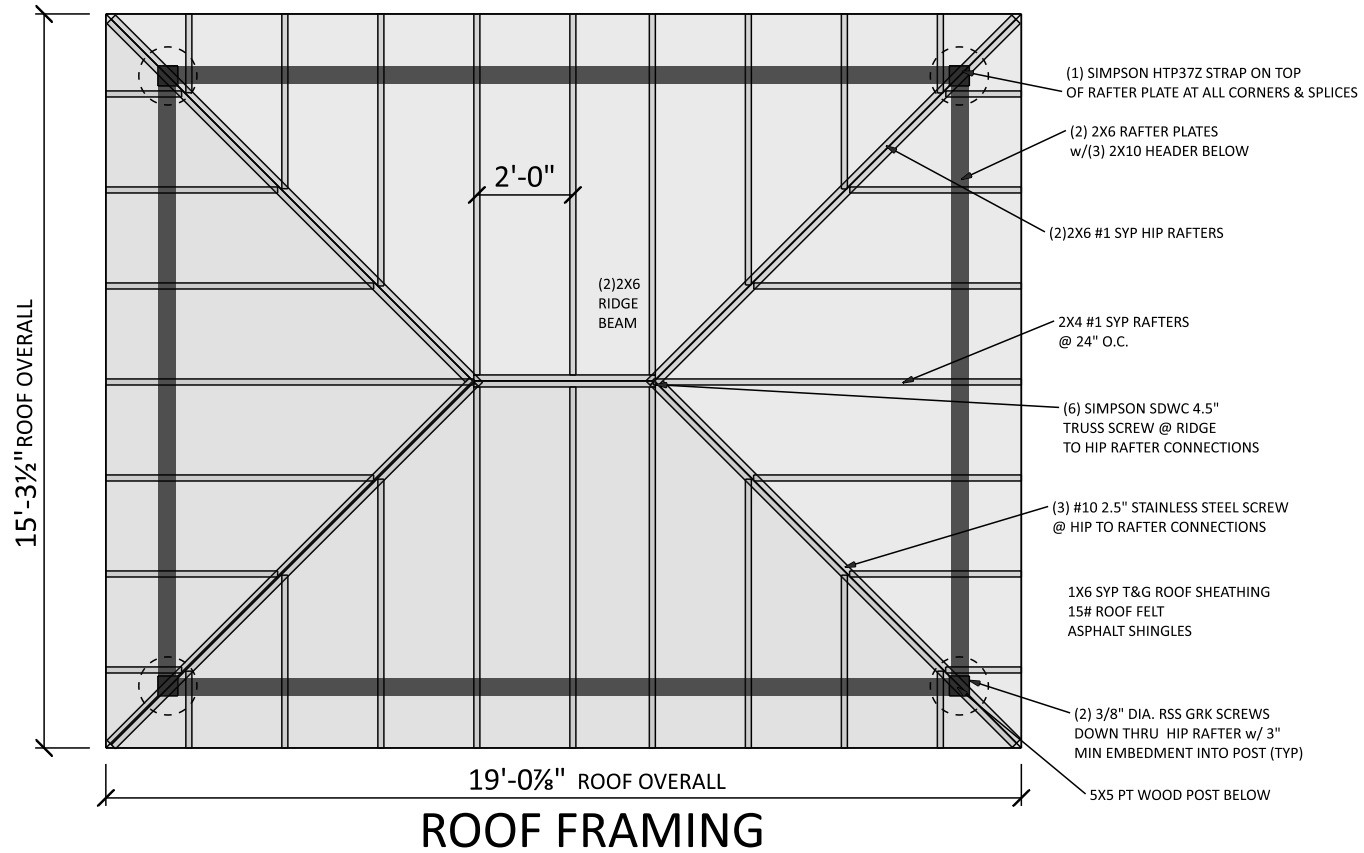

POST LOCATION PLAN

 Creative Gazebos WWW.CREATIVEGAZEBOS.COM	SITE LOCATION:	14 x 18 Keystone Pavilion (4 post)	
		DATE: Monday, March 25, 2024	
		SCALE: 1/4" = 1'-0"	BY: MERVIN E
			PAGE: 2

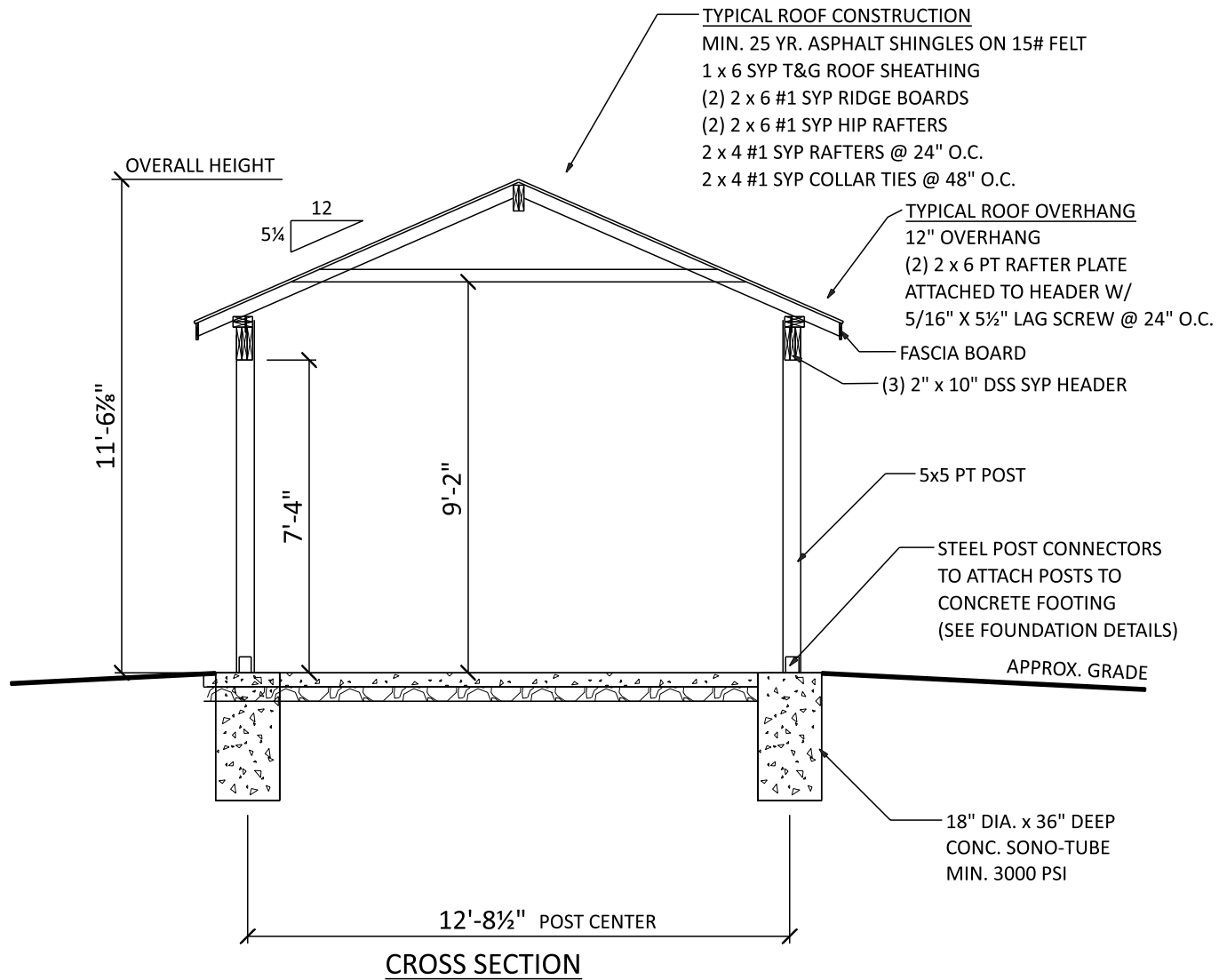

 Creative Gazebos WWW.CREATIVEGAZEBOS.COM	SITE LOCATION:	14 x 18 Keystone Pavilion (4 post)	
		DATE: Monday, March 25, 2024	
		SCALE: 1/4" = 1'-0"	BY: MERVIN E
		PAGE: 3	



 Creative Gazebos WWW.CREATIVEGAZEBOS.COM	SITE LOCATION:	14 x 18 Keystone Pavilion (4 post)	
		DATE: Monday, March 25, 2024	
		SCALE: 1/4" = 1'-0"	BY: MERVIN E
		PAGE: 4	

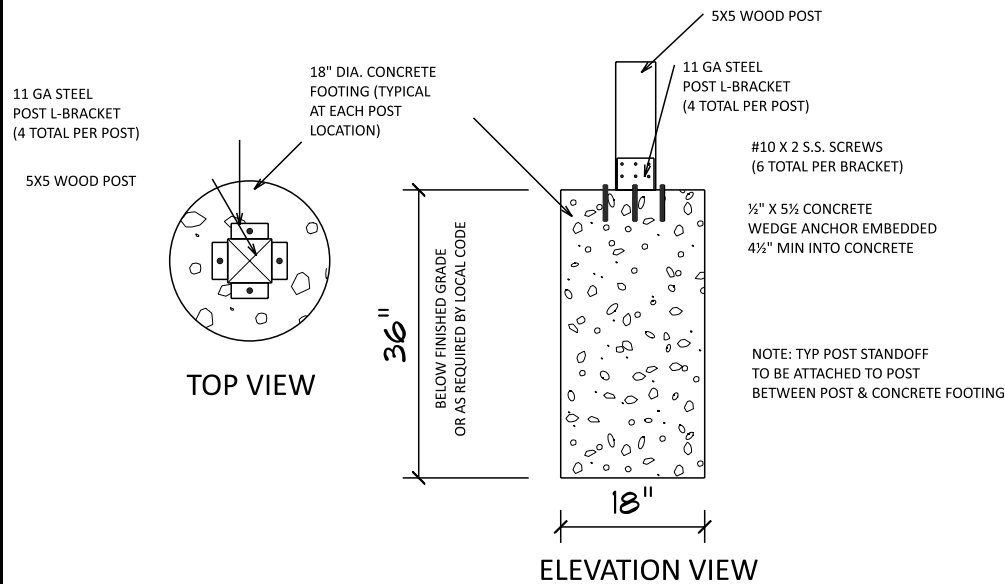

FOUNDATION DETAILS

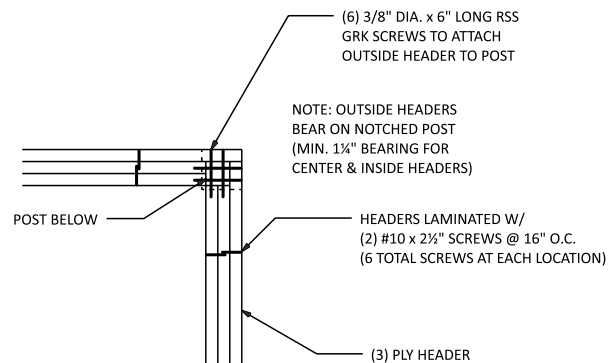
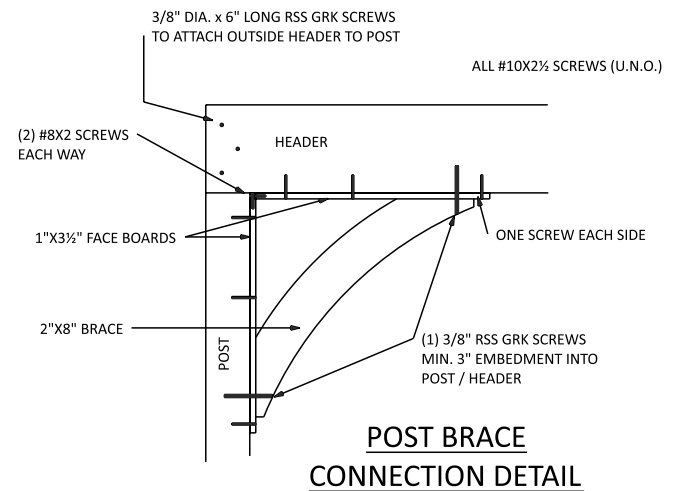

HEADER TO CORNER POST CONNECTION DETAIL

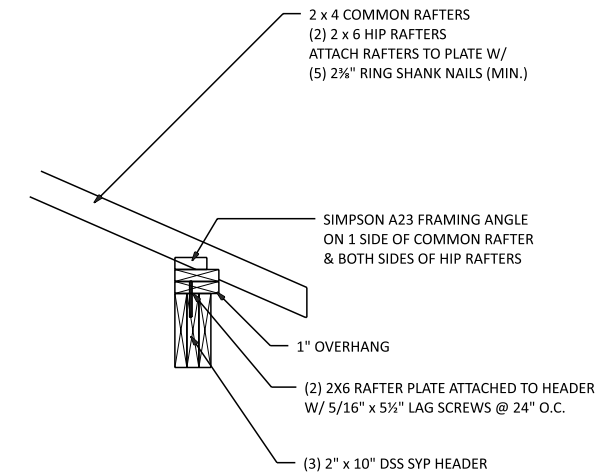

RAFTER CONNECTION DETAIL

 Creative Gazebos WWW.CREATIVEGAZEBOS.COM	SITE LOCATION:	14 x 18 Keystone Pavilion (4 post)	
		DATE: Monday, March 25, 2024	
		SCALE: 1/2" = 1'-0"	BY: MERVIN E